



**WARNING:**

Validate the kit contents with the component list before proceeding. This kit is intended to be used in a modified vehicle. Please read this sheet thoroughly and be sure that you understand everything explained on it prior to opening any of the enclosed packages, or before attempting to install any of the components. Once this kit has been opened or a component installed, the kit is not returnable.

The enclosed instructions show the connections to typical switches. Before beginning, it is important to consider the following:

1. This kit should typically be used in a MODIFIED application only.
2. This kit and all accessories that connect to this kit must be rated at 12 volts.
3. This kit supports the use of a high current self-exciting 1-wire alternator or other style internally regulated alternators. An adapter may be necessary in some applications.
4. This kit **WILL NOT** support the wiring for an ammeter gauge.
5. This kit **DOES NOT INCLUDE** Headlight, Ignition, or Dimmer switches. See page 3 for a list of optional switch kits available for use with this kit.
6. This kit **DOES NOT INCLUDE** battery cables. See the American Autowire catalog for optional Battery Cable kits.
7. There is no set pattern on how the wire is routed to each switch. Wire routing is an individual preference and therefore it is the responsibility of the installer to design the wire routing scheme for the specific vehicle. The important thing about wire routing is to consider the neatest bundle and the shortest distance. Extra wire should be eliminated once the desired routing has been measured. Excess wire should never be coiled and bundled out of the way.
8. There is more wire than required for the circuits in question. With this in mind, each wired circuit should be routed and measured before the wire is cut and terminated.
9. Printed wires will have the same color coding as on the drawings and a circuit description printed on the wire every 3 inches.
10. Each wire requiring termination is identified with it's terminal, which is letter coded. These letter coded terminals are shown in actual size in the loose piece terminal kit 510631. Wires are shown approaching the terminal as it would appear before termination.
11. It is recommended that the proper crimp tool be used for the terminal installations. With the correct crimp tool, soldering the termination would not be necessary. However, when in doubt about the integrity of the termination, it is recommended that the connection be soldered.
12. There are connections within some circuits that are best handled with an "in-line splice". The physical location of the splice is up to the installer as it is dependent on the wire routing scheme. It is strongly recommended that any "in-line splice" connection be soldered before sealing the connection with shrink tubing. Be sure to install the wires through the shrink tubing before crimping and soldering the splice connection.
13. **Disconnect the battery before installing the wiring kit to prevent any accidental shorting caused by loose bare wire ends.**

**TABLE OF CONTENTS**

This kit is broken down into individual sections that are identified by a letter printed on the identification sheet visible through each bag. The order of installation is shown below. The main instruction sheet will show the interface of all the subkits for the complete vehicle. The 510631 - Connector and Terminal Loose Piece Kit contains the connectors and terminals used by all the subkits.

<u>Bag</u>	<u>Kit #</u>	<u>Sub-Kit Function</u>
A.	510626	Main Fuse Panel - Contains power circuits for: - Headlight Switch - Turn Signal Switch - Hazard Signal Switch - Horn - Windshield Wipers - Spare Battery - Ignition Switch - Main Battery Power - Stop and Courtesy lights - Heater - Gauge Panel Power - Spare Accessory
B.	510627	Steering Column and Turn Signal Subkit - Contains wiring for: - Dash Directional Lights - Turn Signal Switch - Front Turn Signal Lights - Rear Turn Signal Lights - Brake Switch and Lights - Emergency Hazard Lights
C.	510628	Vehicle Lighting Subkit - Contains wiring for: - Headlights - Front and Rear Running Lights - High Beam Indicator Light - Headlight Switch - Headlight Dimmer Switch - Rear License Light
D.	510629	Gauge Connection Subkit - Contains wiring for: - Instrument Cluster Lights - Oil Pressure Gauge - Engine Water Temperature - Fuel Gauge and Sender - High Beam Indicator Light - Instrument Cluster Ignition Power
E.	510630	Alternator, Starter, and Ignition Subkit - Contains wiring for: - Ignition Switch - Starter Connection - Main Power Connections - Alternator Connection - Distributor and Coil
F.	510631	Connector and Terminal Loose Piece Kit - Contains connectors and terminals used in all subkits.
92971504		Instruction Sheet for 510625



**American  
Autowire**

www.americanautowire.com 856-933-0801

**510625**

ROUTE 9 WIRING KIT

92971504 Rev 2.2 6/11/2018

# START HERE !

## PLEASE READ THIS BEFORE STARTING INSTALLATION !

This wiring kit is designed for ease of installation. Please read the guidelines below, BEFORE STARTING your installation, to guarantee a successful job. Use an appropriate crimping tool, which folds the wings of the open barrel terminals down into the wire, as shown on this page. If you use our crimping tools and correctly crimp the included terminals, soldering is not necessary. If you are unsure about a particular crimp, soldering is recommended. Our factory crimped terminations are installed by GM approved five ton presses, and soldering these terminations is not necessary.



AAW offers a great terminal crimping video entitled "Proper Crimping Video". It can be viewed by visiting YouTube.

Type the following address into your web browser, to go directly to the video:  
<https://www.youtube.com/watch?v=JAgEDoVI-co>

Youtube Channel:  
[www.youtube.com/user/WiringHarness](http://www.youtube.com/user/WiringHarness)



If you have any questions concerning this or any of our products, please feel free to call us at 1-856-933-0801.

The terminals that we supply in our kits, utilize what is known as an "F" crimp. The "F" crimp, in a cross section, will look like the illustration below, when done correctly.

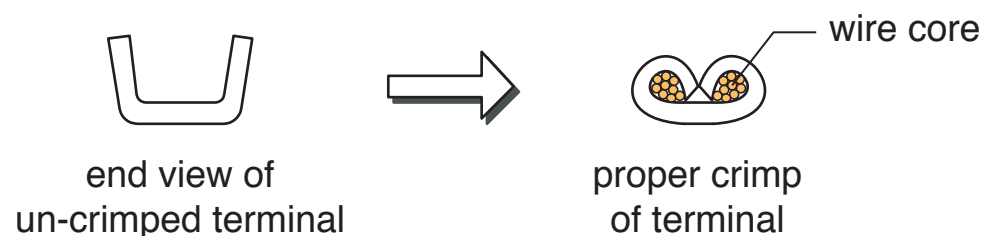

We carry the following crimping hand tools, to help with your terminal crimping. These hand tools are available for purchase or rental.

AAW p/n 510585  
OEM small terminal crimping  
tool (18-14 gauge)



AAW p/n 510586  
OEM large terminal crimping  
tool (12-8 gauge)



AAW p/n 510609  
Weather Pack/Metri Pack  
crimping tool (18-12 gauge)



**510625**

ROUTE 9 WIRING KIT

## OPTIONAL ADD-ON KITS THAT ARE DESIGNED FOR USE WITH THIS KIT

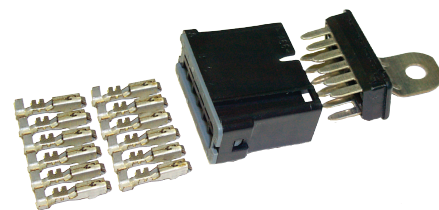

Universal Ground Splice System  
Part# 500544



Master Disconnect Switch  
Part# 500003

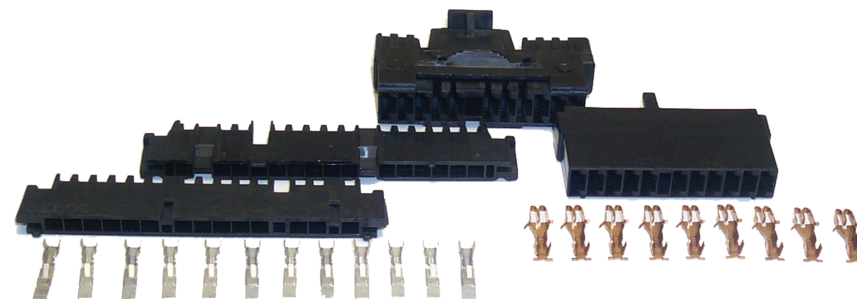

GM Column Turn Signal Connector  
Part# 500428

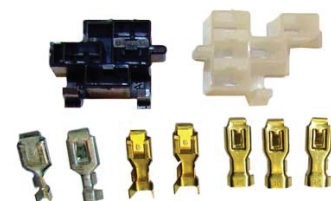

Column Mounted Ignition Switch Connector  
Part# 500257

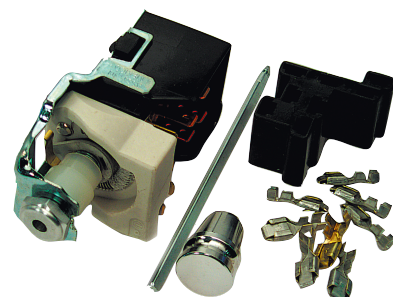

Headlight Switch - Part# 500341

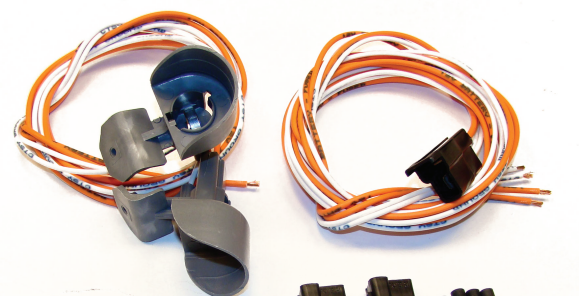

Courtesy Light Connection Kit  
Part# 500081

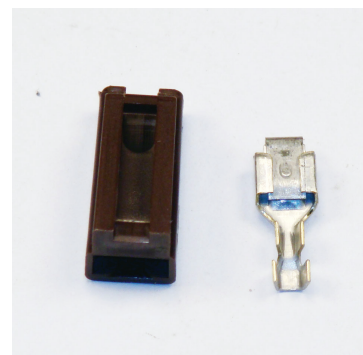

GM HEI Tach. Connector  
Part# 500205

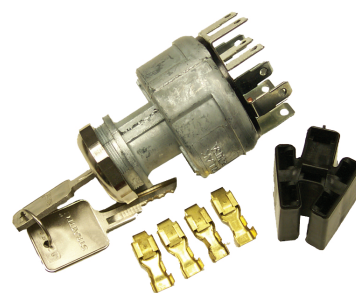

Ignition Switch & Connectors  
Part# 500456

Battery Cable Kits

Part# 500723

Part# 500724

Part# 500725

Part# 500726

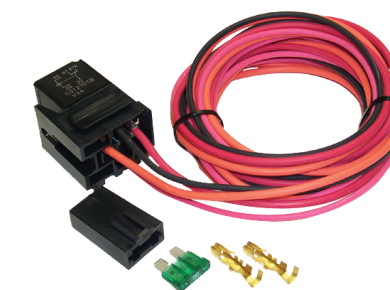

Electric Fan Relay Kit  
Part# 500479



GM HEI Ignition Connector  
Part# 500204



Dimmer Switch - Part# 500042  
Connector & Terminals - Part# 500286



Master Disconnect Switch  
Part# 500930



Electronic Speedometer Kit  
Part# 510644



**American  
Autowire**

www.americanautowire.com 856-933-0801

**510625**

ROUTE 9 WIRING KIT

92971504 Rev 2.2 6/11/2018

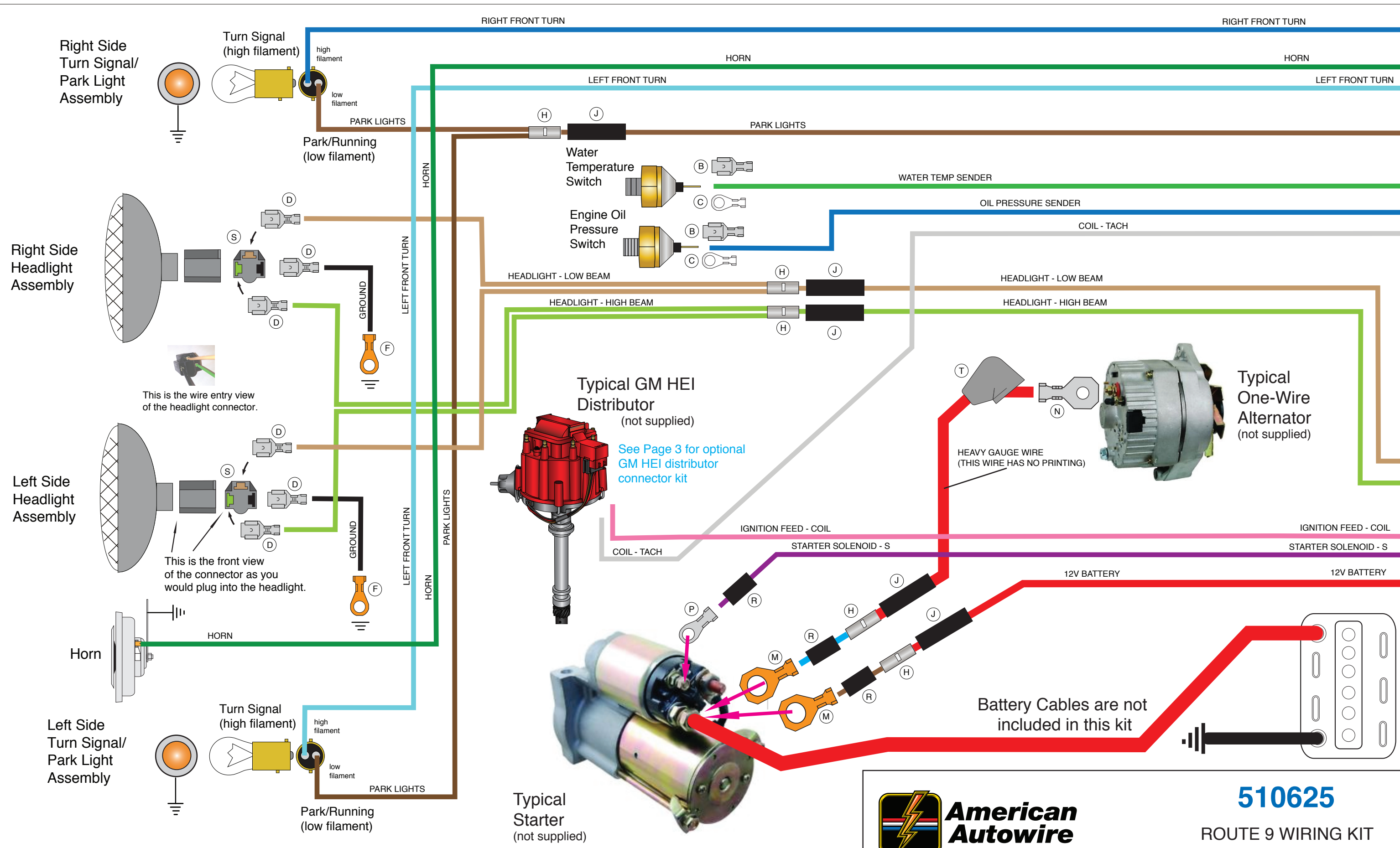

**510625**

ROUTE 9 WIRING KIT

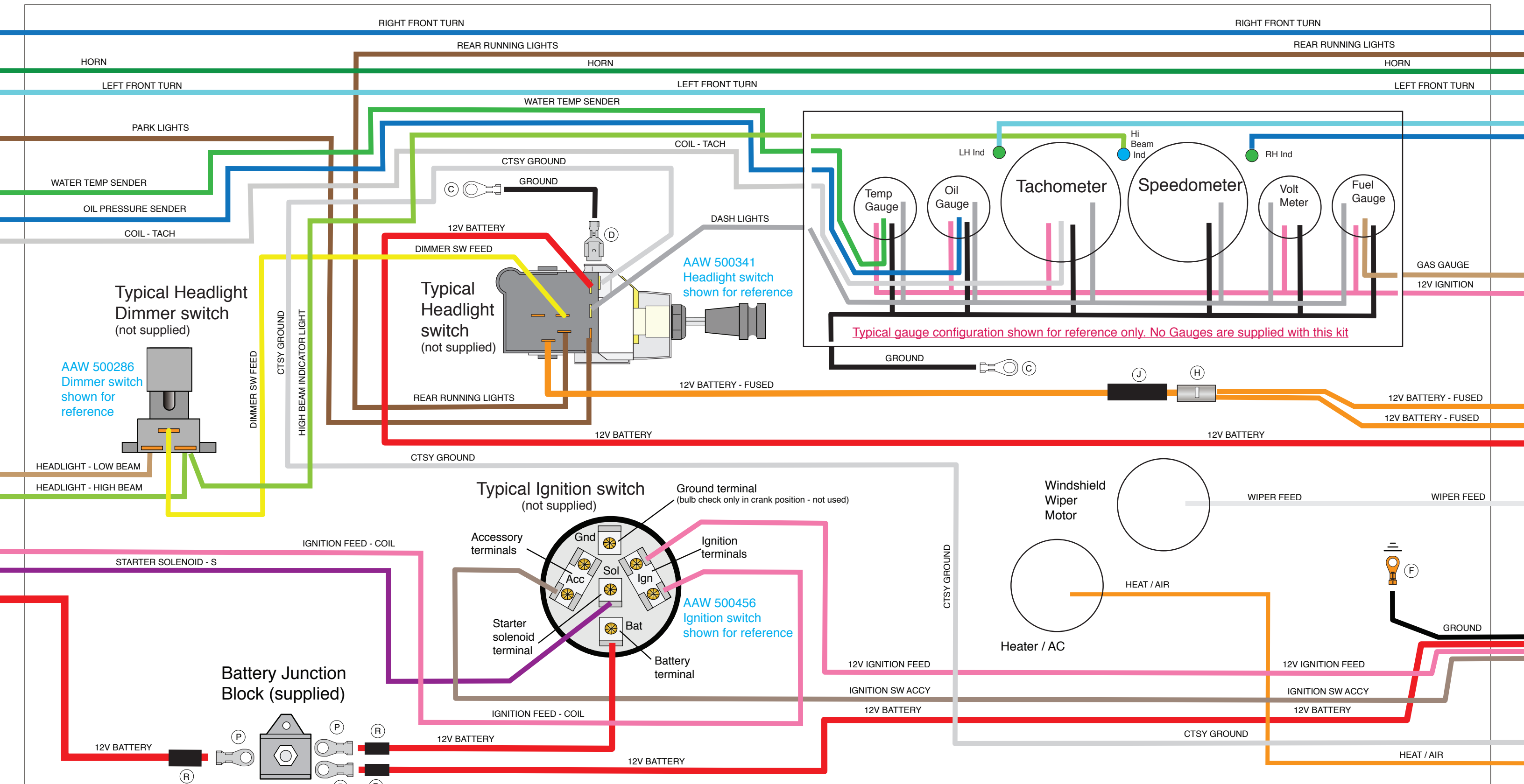

Typical gauge configuration shown for reference only. No Gauges are supplied with this kit



**American  
Autowire**

www.americanautowire.com 856-933-0801

**510625**

ROUTE 9 WIRING KIT

92971504 Rev 2.2 6/11/2018

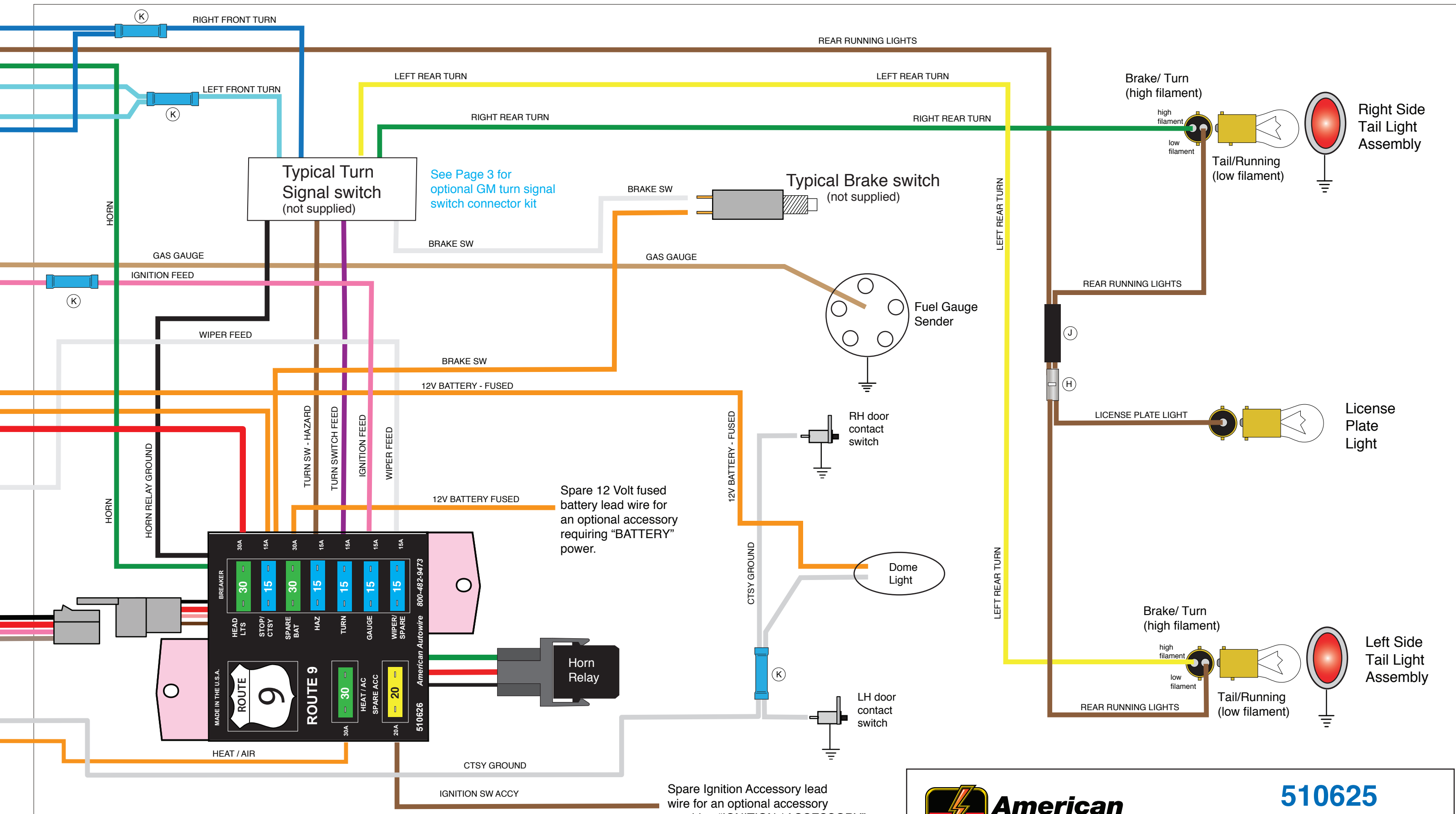



**American  
Autowire**

www.americanautowire.com 856-933-0801

**510625**

**ROUTE 9 WIRING KIT**

92971504 Rev 2.2 6/11/2018